

Operator's Manual

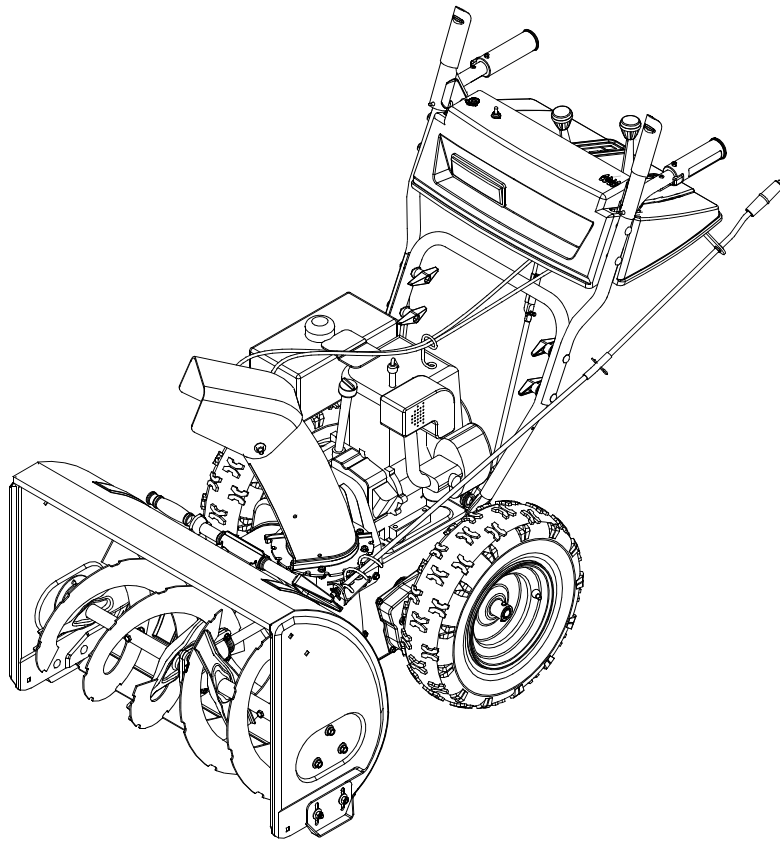

Snow Thrower Model H660G

IMPORTANT: READ SAFETY RULES AND INSTRUCTIONS CAREFULLY

Warning: This unit is equipped with an internal combustion engine and should not be used on or near any unimproved forest-covered, brush-covered or grass-covered land unless the engine's exhaust system is equipped with a spark arrester meeting applicable local or state laws (if any). If a spark arrester is used, it should be maintained in effective working order by the operator. In the State of California the above is required by law (Section 4442 of the California Public Resources Code). Other states may have similar laws. Federal laws apply on federal lands. A spark arrester for the muffler is available through your nearest engine authorized service dealer or contact the service department, P.O. Box 361131 Cleveland, Ohio 44136-9722.

MTD LLC, P.O. BOX 361131 CLEVELAND, OHIO 44136-9722

TABLE OF CONTENTS

Content	Page
Important Safe Operation Practices	3
Assembling Your Snow Thrower	5
Know Your Snow Thrower	6
Operating Your Snow Thrower	8
Making Adjustments	11
Maintaining Your Snow Thrower	13
Service	14
Off-Season Storage.....	16
Troubleshooting	17
Parts List	18

FINDING MODEL NUMBER

This Operator's Manual is an important part of your new snow thrower. It will help you assemble, prepare and maintain the unit for best performance. Please read and understand what it says.

Before you start assembling your new equipment, please locate the model plate on the equipment and copy the information from it in the space provided below. The information on the model plate is very important if you need help from our Customer Support Department or an authorized dealer.



You can locate the model number by standing behind the unit in the operating position and looking down at the rear frame below the engine. A sample model plate is explained below. For future reference, please copy the model number and the serial number of the equipment in the space below.

_____ (Model Number)

_____ (Serial Number)



MTD LLC
P. O. BOX 361131
CLEVELAND, OH 44136
330-220-4683
800-800-7310

Copy the model number here: _____

Copy the serial number here: _____

ENGINE INFORMATION

The engine manufacturer is responsible for all engine-related issues with regard to performance, power-rating, specifications, warranty and service. Please refer to the engine manufacturer's Owner's/Operator's Manual packed separately with your unit for more information.

CALLING CUSTOMER SUPPORT

Please do NOT return the unit to the retailer from which it was purchased, without first contacting Customer Support.

Should you have difficulty assembling this product or have any questions regarding the controls, operation or maintenance of this unit, please call the Customer Support Department.



Call **1- (330) 220-4MTD (4683)** or **1- (800) 800-7310** to reach a Customer Support representative. Please have your unit's model number and serial number ready when you call. See previous section to locate this information. You will be asked to enter the serial number in order to process your call.

For more details about your unit, visit our website at www.mtdproducts.com

SECTION 1: IMPORTANT SAFE OPERATION PRACTICES



This symbol points out important safety instructions, which if not followed, could endanger the personal safety and/or property of yourself and others. Read and follow all instructions in this manual before attempting to operate this machine. Failure to comply with these instructions may result in personal injury. When you see this symbol—**heed its warning**.



WARNING: Engine Exhaust, some of its constituents, and certain vehicle components contain or emit chemicals known to the State of California to cause cancer, birth defects or other reproductive harm.



DANGER: This machine was built to be operated according to the rules for safe operation in this manual. As with any type of power equipment, carelessness or error on the part of the operator can result in serious injury. This machine is capable of amputating hands and feet and throwing objects. Failure to observe the following safety instructions could result in serious injury or death.

TRAINING

1. Read, understand, and follow all instructions on the machine and in the manual(s) before attempting to assemble and operate. Keep this manual in a safe place for future and regular reference and for ordering replacement parts.
 2. Be familiar with all controls and their proper operation. Know how to stop the machine and disengage them quickly.
 3. Never allow children under 14 years old to operate this machine. Children 14 years old and over should read and understand the operation instructions and safety rules in this manual and should be trained and supervised by a parent.
 4. Never allow adults to operate this machine without proper instruction.
 5. Thrown objects can cause serious personal injury. Plan your snow-throwing pattern to avoid discharge of material toward roads, bystanders and the like.
 6. Keep bystanders, helpers, pets and children at least 75 feet from the machine while it is in operation. Stop machine if anyone enters the area.
 7. Exercise caution to avoid slipping or falling, especially when operating in reverse.
7. Never attempt to make any adjustments while engine is running, except where specifically recommended in the operator's manual.
 8. Let engine and machine adjust to outdoor temperature before starting to clear snow.
 9. To avoid personal injury or property damage use extreme care in handling gasoline. Gasoline is extremely flammable and the vapors are explosive. Serious personal injury can occur when gasoline is spilled on yourself or your clothes, which can ignite. Wash your skin and change clothes immediately.
 - a. Use only an approved gasoline container.
 - b. Extinguish all cigarettes, cigars, pipes and other sources of ignition.
 - c. Never fuel machine indoors.
 - d. Never remove gas cap or add fuel while the engine is hot or running.
 - e. Allow engine to cool at least two minutes before refueling.
 - f. Never over fill fuel tank. Fill tank to no more than ½ inch below bottom of filler neck to provide space for fuel expansion.
 - g. Replace gasoline cap and tighten securely.
 - h. If gasoline is spilled, wipe it off the engine and equipment. Move machine to another area. Wait 5 minutes before starting the engine.
 - i. Never store the machine or fuel container inside where there is an open flame, spark or pilot light (e.g. furnace, water heater, space heater, clothes dryer etc.).
 - j. Allow machine to cool at least 5 minutes before storing.

PREPARATION

1. Thoroughly inspect the area where the equipment is to be used. Remove all doormats, newspapers, sleds, boards, wires and other foreign objects, which could be tripped over or thrown by the auger/impeller.
2. Always wear safety glasses or eye shields during operation and while performing an adjustment or repair to protect your eyes. Thrown objects which ricochet can cause serious injury to the eyes.
3. Do not operate without wearing adequate winter outer garments. Do not wear jewelry, long scarves or other loose clothing, which could become entangled in moving parts. Wear footwear which will improve footing on slippery surfaces.
4. Use a grounded three-wire extension cord and receptacle for all units with electric start engines.
5. Adjust collector housing height to clear gravel or crushed rock surfaces.
6. Disengage all clutch levers before starting the engine.

OPERATION

1. Do not put hands or feet near rotating parts, in the auger/impeller housing or discharge chute. Contact with the rotating parts can amputate hands and feet.
2. The auger/impeller clutch lever is a safety device. Never bypass its operation. Doing so makes the machine unsafe and may cause personal injury.
3. The clutch levers must operate easily in both directions and automatically return to the disengaged position when released.
4. Never operate with a missing or damaged discharge chute. Keep all safety devices in place and working.

5. Never run an engine indoors or in a poorly ventilated area. Engine exhaust contains carbon monoxide, an odorless and deadly gas.
6. Do not operate machine while under the influence of alcohol or drugs.
7. Muffler and engine become hot and can cause a burn. Do not touch.
8. Exercise extreme caution when operating on or crossing gravel surfaces. Stay alert for hidden hazards or traffic.
9. Exercise caution when changing direction and while operating on slopes.
10. Plan your snow-throwing pattern to avoid discharge towards windows, walls, cars etc. Thus, avoiding possible property damage or personal injury caused by a ricochet.
11. Never direct discharge at children, bystanders and pets or allow anyone in front of the machine.
12. Do not overload machine capacity by attempting to clear snow at too fast of a rate.
13. Never operate this machine without good visibility or light. Always be sure of your footing and keep a firm hold on the handles. Walk, never run.
14. Disengage power to the auger/impeller when transporting or not in use.
15. Never operate machine at high transport speeds on slippery surfaces. Look down and behind and use care when in reverse.
16. If the machine should start to vibrate abnormally, stop the engine, disconnect the spark plug wire and ground it against the engine. Inspect thoroughly for damage. Repair any damage before starting and operating.
17. Disengage all clutch levers and stop engine before you leave the operating position (behind the handles). Wait until the auger/impeller comes to a complete stop before unclogging the discharge chute, making any adjustments, or inspections.
18. Never put your hand in the discharge or collector openings. Always use the clean-out tool provided to unclog the discharge opening. Do not unclog discharge chute while engine is running. Shut off engine and remain behind handles until all moving parts have stopped before unclogging.
19. Use only attachments and accessories approved by the manufacturer (e.g. wheel weights, tire chains, cabs etc.).
20. If situations occur which are not covered in this manual, use care and good judgment. Contact your dealer or telephone 1-800-800-7310 for assistance and the name of your nearest servicing dealer.

MAINTENANCE AND STORAGE

1. Never tamper with safety devices. Check their proper operation regularly. Refer to the maintenance and adjustment sections of this manual.
2. Before cleaning, repairing or inspecting machine disengage all clutch levers and stop engine. Wait until the auger/impeller come to a complete stop. Disconnect the spark plug wire and ground against the engine to prevent unintended starting.
3. Check bolts and screws for proper tightness at frequent intervals to keep the machine in safe working condition. Also, visually inspect machine for any damage.
4. Do not change the engine governor setting or over-speed the engine. The governor controls the maximum safe operating speed of the engine.
5. Snow thrower shave plates and skid shoes are subject to wear and damage. For your safety protection, frequently check all components and replace with original equipment manufacturer's (OEM) parts only. "Use of parts which do not meet the original equipment specifications may lead to improper performance and compromise safety!"
6. Check clutch controls periodically to verify they engage and disengage properly and adjust, if necessary. Refer to the adjustment section in this operator's manual for instructions.
7. Maintain or replace safety and instruction labels, as necessary.
8. Observe proper disposal laws and regulations for gas, oil, etc. to protect the environment.
9. Prior to storing, run machine a few minutes to clear snow from machine and prevent freeze up of auger/impeller.
10. Never store the machine or fuel container inside where there is an open flame, spark or pilot light such as a water heater, furnace, clothes dryer etc.
11. Always refer to the operator's manual for proper instructions on off-season storage.

WARNING — YOUR RESPONSIBILITY:

Restrict the use of this power machine to persons who read, understand and follow the warnings and instructions in this manual and on the machine. The safety labels are shown below for your reference.

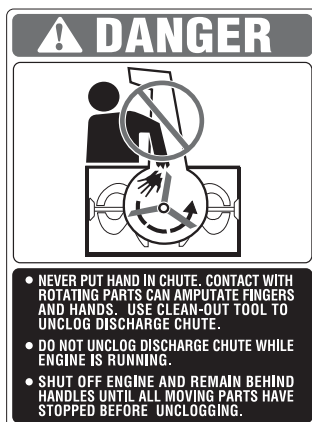

SECTION 2: ASSEMBLING YOUR SNOW THROWER

Loose Parts

The augers are secured to the auger shaft with two shear bolts and hex lock nuts. If you hit a foreign object or ice jam, the snow thrower is designed so that the bolts may shear. Two replacement shear bolts and nuts are provided for your convenience. Store in a safe place until needed. See Figure 1.

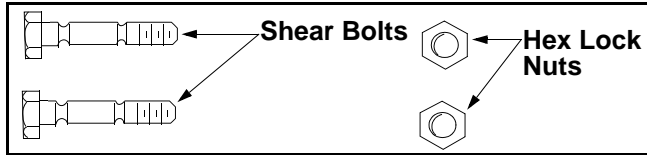

Figure 1

Assembly



WARNING: Disconnect spark plug wire and ground it against the engine to prevent unintended starting.

NOTE: All references to right or left side of the snow thrower are determined from behind the unit in the operating position. The “operator’s position” is defined as standing directly behind the snow thrower, facing the handle panel.

- Remove the **lower** two plastic wing knobs, cupped washers and carriage bolt (eyebolt on the left side) from the lower handle. See Figure 2.

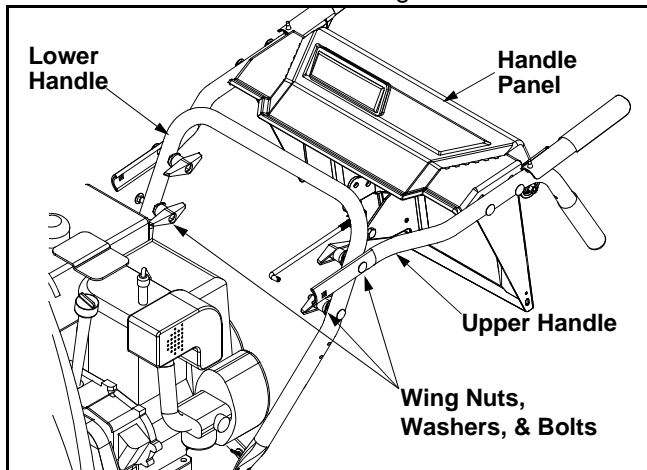

Figure 2

- Raise the upper handle assembly until it locks over the lower handle. See Figure 3.
- Observe the lower rear area of the snow thrower to be sure both cables are aligned with roller guides.
- Secure the upper handle and lower handle with the two plastic wing knobs, cupped washers and carriage bolt (eyebolt on the left side) previously removed. See Figure 3.

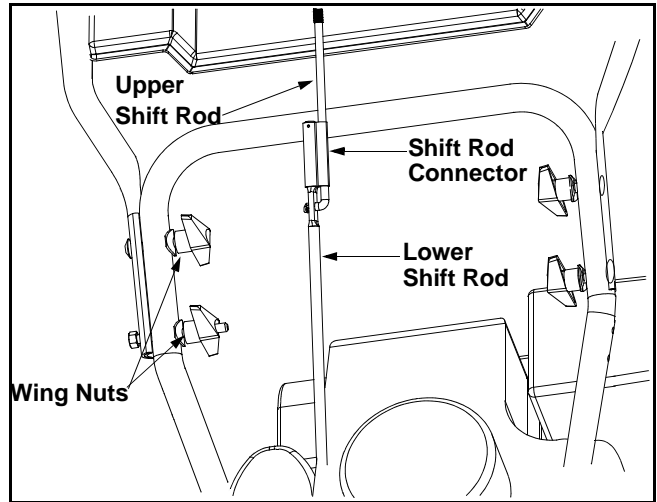

Figure 3

- Slide the connector down over the end of the lower shift rod. See Figure 3. Tap the connector until it **locks** on the lower shift rod.

If the connector is not properly assembled, the shift rod will pivot and you will not be able to change speeds or change directions.

- Thread the jam nuts all the way up each of the “Z” fittings, toward the handle panel. See Figure 4.

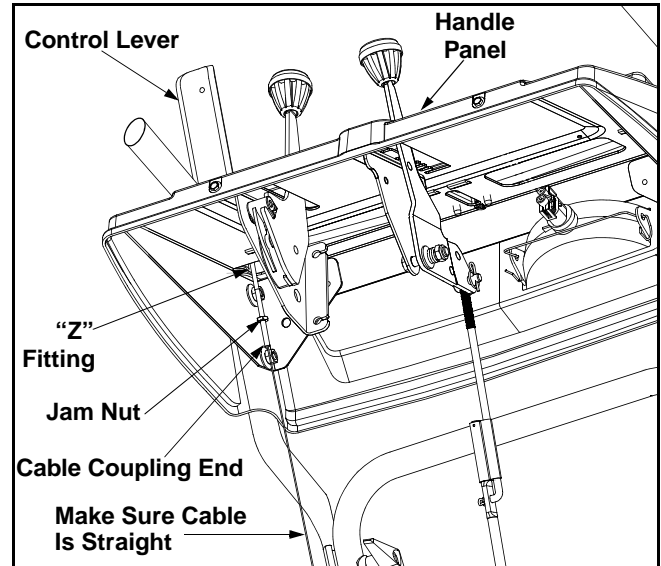

Figure 4

- Make certain all cables are in the grooves of the cable roller guides located in the lower rear of the unit, one on each side.
- Thread the coupling end of the cable onto the threaded portion of the “Z” fitting until the rubber bumper (located on the underside of the control lever) only lightly contacts the upper handle.

IMPORTANT: The cable should have very little slack, but should NOT be tight. An overtightened cable may prohibit the auger and drive from disengaging.



WARNING: Over-tightening the cable may prohibit the auger and drive from disengaging and compromise the safety of the snow thrower. Do NOT overtighten the cable.

- Once properly adjusted, tighten the jam nut against the coupling end of the cable to lock it in position. Refer to **Auger Control Test** on page 9 prior to operating your snow thrower. Read and follow all instructions carefully and perform all adjustments to verify your snow thrower is operating safely and properly.
- If not already attached, slip the cables that run from the handle panel to the chute into the cable guide located on top of the engine. See Figure 5.

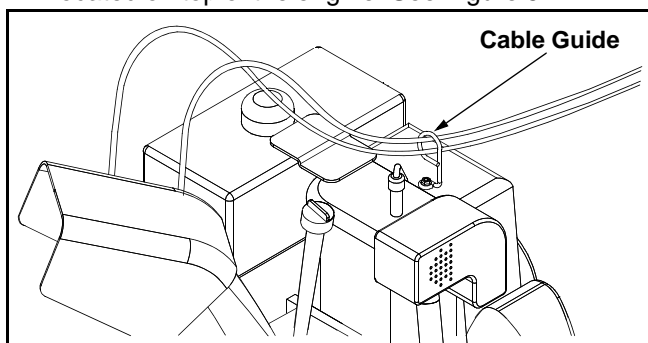

Figure 5

- Unwrap the headlight wire, which is attached to the headlight beneath the handle panel.
- Wind the headlight wire around the right handle until excess slack is removed.
- Plug the wire from the headlight into the wire lead coming from the right side of the engine, beneath the fuel tank. See Figure 6.

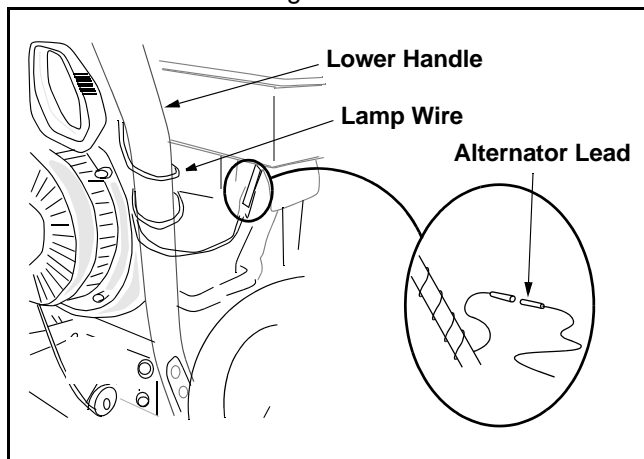

Figure 6

SECTION 3: KNOW YOUR SNOW THROWER



WARNING: Be familiar with all controls and their proper operation. Know how to stop the machine and disengage them quickly.

Shift Lever

The shift lever is located in the center of the handle panel. The shift lever may be moved into one of eight positions. Run engine with throttle in the fast position. Use the shift lever to determine ground speed.

Forward: There are six speeds. Position one (1) is the slowest. Position six (6) is the fastest.

Reverse: There are two reverse (R) speeds R1 and R2. The "R2" closest to the operator (all the way back) is the faster of the two.

Auger/Traction Control

The auger control is located on the left handle. Squeeze the control to engage the augers; release to stop the augers. The traction control must also be released.

The traction control is located on the right handle. Squeeze the control to engage the wheel drive. Release to stop.

Traction / Auger Control Lock

This same control also locks the auger control so you can turn the chute directional control without interrupting the snow throwing process. If the auger control is engaged with the traction control engaged, the operator can release the auger control (on the left handle) and the augers will remain engaged. Release the traction control to stop both the augers and wheel drive (auger control must also be released).

Chute Directional Control

The chute directional control is located on left hand side of the snow thrower. To change the direction in which snow is thrown, rotate chute directional control as follows:

- Clockwise to discharge to the left.
- Counterclockwise to discharge to the right.

Chute Tilt Control

The distance snow is thrown can be changed by adjusting the angle of the chute assembly. Move the chute tilt control forward to decrease the distance, toward the rear to increase. See Figure 7.

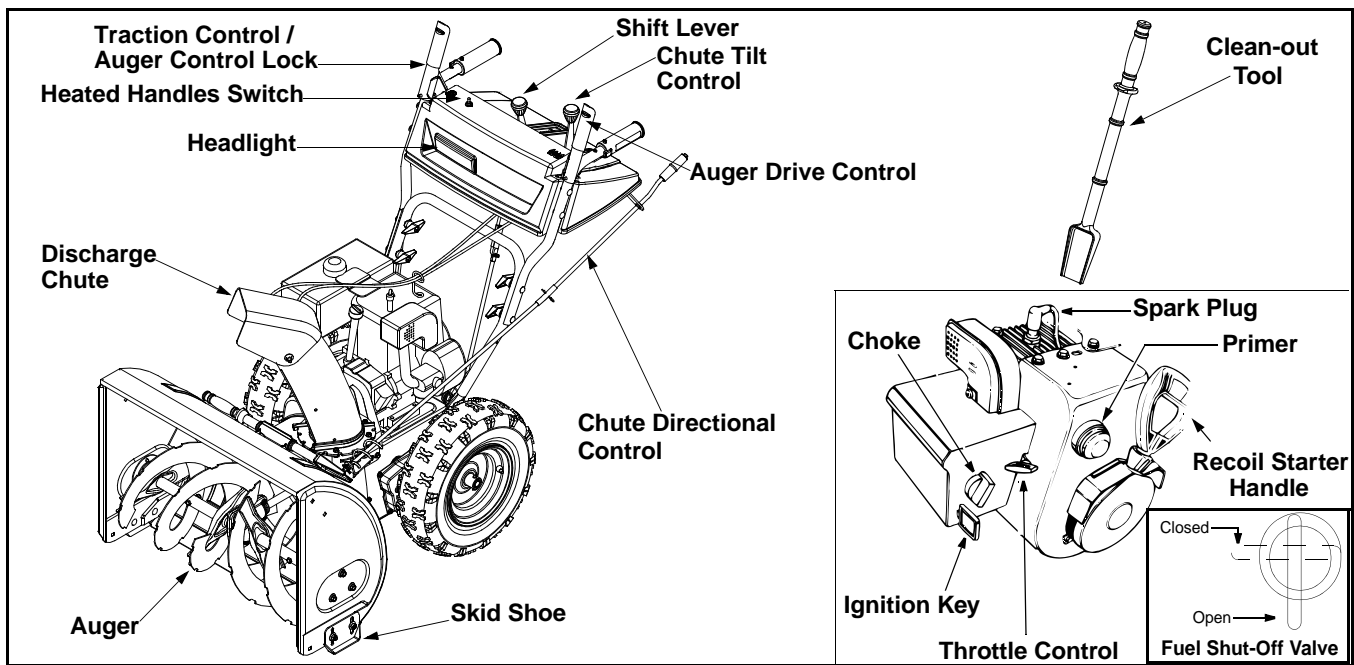

Figure 7

Heated Handles Switch

The heated handles switch is located on the right side of the snow thrower handle panel. To activate the heated handles, toggle the switch to the right to generate heat within the handles. Toggle the heated handles switch to the left into the OFF position after using the snow thrower.

The heated handles are a compliment to, not a substitute for, proper cold weather outerwear for hands. It is recommended that the user wear adequate winter protection for hands (like gloves/mittens) when operating this snow thrower.

Headlight

The headlight is on whenever the engine is running.

Chute Clean-Out Tool



WARNING: Never use your hand to clear a clogged discharge chute. Shut off engine and remain behind handles until all moving parts have stopped before unclogging.

The chute clean-out tool (see Figure 7) is designed to clear a clogged discharge chute. Refer to **Operating Your Snow Thrower** on page 10 for detailed instructions on how to properly use the chute clean-out tool.

NOTE: This item is fastened with a cable tie to the rear of the Auger Housing at the factory. Cut the cable tie before operating the snow thrower.

Ignition Key

The ignition key must be inserted in the switch in order for the engine to start. Remove the ignition key when the snow thrower is not in use.

NOTE: Do NOT “turn” the ignition key in an attempt to start the engine. Doing so may cause it to break.

Fuel Shut-Off Valve (optional equipment)

On models so equipped, the fuel shut-off valve, located under fuel tank, controls fuel-flow from the gas tank. See Figure 7.

Throttle Control

The throttle control is located on the engine. It regulates the speed of the engine. See Figure 7.

Skid Shoe

The position of the skid shoe is determined by the condition of the ground from where snow has to be removed. See Figure 7.

SECTION 4: OPERATING YOUR SNOW THROWER

Before Starting



WARNING: Read, understand, and follow all instructions and warnings on the machine and in this manual before operating.

- The spark plug wire was disconnected for safety. Attach spark plug wire to spark plug before starting.

Gas And Oil Fill-up

- At the factory, a plastic **cup** is inserted inside the fuel tank's fill opening (beneath the fuel cap) to prevent debris from entering the fuel tank during assembly. Remove and discard this cup before filling up the tank.



WARNING: Use extreme care when handling gasoline. Gasoline is extremely flammable and the vapors are explosive. Never fuel machine indoor or while the engine is hot or running. Extinguish cigarettes, cigars, pipes and other sources of ignition.

Starting Engine



IMPORTANT: Prior to operating your snow thrower, read, understand and follow ALL instructions to perform adjustments found under the heading **Auger Control Test** on page 9 of this manual.

- Attach spark plug wire to spark plug. Make certain the metal loop on end of the spark plug wire (inside the boot) is fastened securely over the metal tip on the spark plug. See Figure 8.

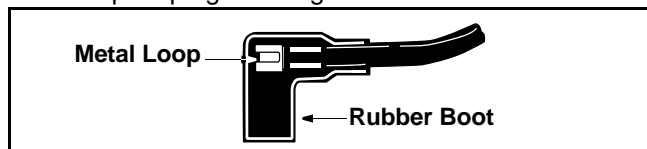

Figure 8

- Make certain the fuel shut-off valve, if so equipped, is in the OPEN (vertical) position.
- Make certain the auger and traction controls are in the disengaged (released) position.
- Move throttle control up to FAST position. Insert ignition key into slot. Be certain it snaps into place. Do not turn key. See Figure 7.

NOTE: Engine will not start unless ignition key is inserted into ignition slot in carburetor cover. Do not turn ignition key.

Recoil Starter:

- Rotate choke knob to FULL choke position (cold engine start).
- If engine is warm, place choke in OFF position instead of FULL.
- Push primer button three or four times for cold engine start. DO NOT use primer to restart a warm engine after a short shutdown.

NOTE: Always cover vent hole in primer button when pushing. Additional priming may be necessary for first start if temperature is below 15 degrees Fahrenheit.

- Grasp starter handle and pull rope out slowly, until it pulls slightly harder. Let rope rewind slowly.
- Pull starter handle rapidly. Do not allow handle to snap back. Allow it to rewind slowly while keeping a firm hold on the starter handle.
- Repeat step above until engine starts.
- As engine warms up and begins to operate evenly, rotate choke knob slowly to OFF position. If engine falters, return to FULL choke, then slowly move to OFF position.

Electric Starter

The electric starter is equipped with a grounded three-wire power cord and plug, and is designed to operate on 120 volt AC household current.



WARNING: The electric starter must be used with a properly grounded three-prong receptacle at all times to avoid possibility of electric shock. Follow all instructions carefully to operate the electric starter.

- Determine that your house wiring is a three-wire grounded system. Ask a licensed electrician if you are not certain.
- **If your home wiring system is not a three-wire grounded system**, do not use this electric starter under any conditions.
- **If your home electrical system is grounded**, but a three-hole receptacle is not available, one should be installed by a licensed electrician before using the electric starter.
- **If you have a grounded three-prong receptacle**, proceed as follows:
- Connect power cord to switch box on engine. Plug the other end of power cord into a three-prong 120-volt, grounded, AC receptacle.
- Rotate choke knob to FULL choke position (cold engine start). If engine is warm, place choke in OFF position instead of FULL.

- Push primer button two or three times for cold engine start, making sure to cover vent hole in primer button when pushing. DO NOT use primer to restart a warm engine after a short shutdown.
- Push starter button to start engine.
- When engine starts, release starter button and move choke gradually to OFF. If engine falters, move choke immediately to FULL and then gradually to OFF.
- When disconnecting the power cord, always unplug from the three-prong receptacle first, and then from the snow thrower.

To Stop Engine

- To stop engine, remove the ignition key. Do not turn key. Disconnect the spark plug wire from the spark plug to prevent accidental starting while equipment is unattended.

To prevent starter freeze-up:

- Run engine for a few minutes before stopping to help dry off any moisture on the engine.
- **Electric Starter:** Connect power cord to switch box on engine, then to 120 volt AC receptacle. With the engine running, push starter button and spin the starter for several seconds. The unusual sound made by spinning the starter will not harm engine or starter. Disconnect the power cord from receptacle first, and then from switch box.
- **Recoil Starter:** With engine running, pull starter rope with a rapid, continuous full arm stroke three or four times. Pulling the starter rope will produce a loud clattering sound, which is not harmful to the engine or starter.
- Wipe all snow and moisture from the carburetor cover in the area of the control levers. Also, move control levers back and forth several times. Leave throttle control lever in the STOP or OFF position. Leave choke control in the FULL choke position.
- Remove ignition key and disconnect spark plug wire. Do not turn key.

IMPORTANT: Do not lose the ignition key. Keep it in a safe place. Engine will not start without the ignition key.

To Engage Drive

- With the engine running near top speed, move shift lever into one of the five FORWARD positions or two REVERSE positions. Select a speed appropriate for the snow conditions that exist. Use the slower speeds until you are familiar with the operation of the snow thrower.

- Squeeze the auger control and the augers will turn. Release it and the augers will stop.
- Squeeze traction control and the snow thrower will move. Release it and unit will stop. Never move shift lever without releasing traction control.

To Engage Augers

- To engage augers and start throwing snow, squeeze the auger control against the left handle. Release to stop the augers.

Auger Control Test

IMPORTANT: Perform the following test before operating the snow thrower for the first time and at the start of each winter season.

Check the adjustment of the auger control as follows:

- When the auger control is released and in the disengaged “up” position, the cable should have very little slack, but should NOT be tight.



WARNING: Do not over-tighten the cable. Over-tightening may prevent the auger from disengaging and compromise the safety of the snow thrower.

- In a well-ventilated area, start the snow thrower engine as instructed earlier in this section under the heading **Starting Engine**. Make sure the throttle is set in the FAST position.
- While standing in the operator’s position (behind the snow thrower) engage the auger.
- Allow the auger to remain engaged for approximately ten (10) seconds before releasing the auger control. Repeat this several times.
- With the engine running in the FAST position and the auger control lever in the disengaged “up” position, walk to the front of the machine.
- Confirm that the auger has completely stopped rotating and shows NO signs of motion.

IMPORTANT: If the auger shows ANY signs of rotating, immediately return to the operator’s position and shut off the engine. Wait for all moving parts to stop before readjusting the auger control cable.

- To readjust the control cable, loosen the hex jam nut on the auger control cable “Z” fitting.
- Rotate the coupling end of the cable counterclockwise to provide more slack.
- Retighten the hex jam nut. See Figure 9.

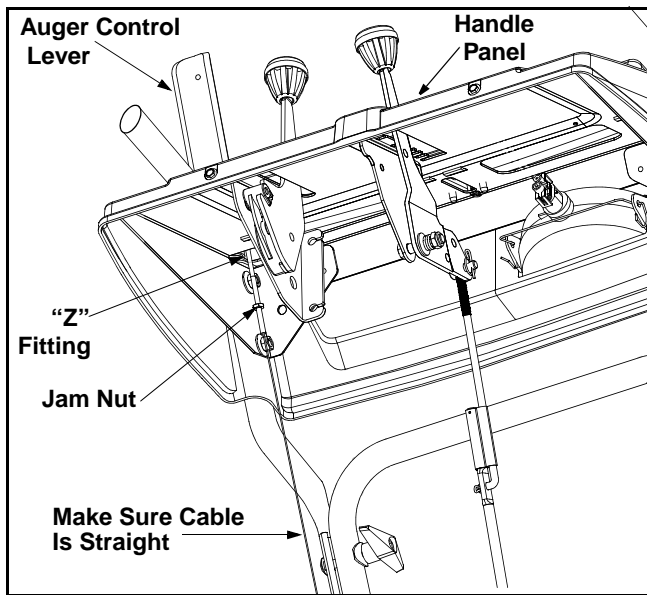

Figure 9

- Repeat Auger Control Test to verify proper adjustment has been achieved.

Chute Clean-Out Tool

The chute clean-out tool is conveniently fastened to the rear of the auger housing with a mounting clip (Refer to Figure 7). If the discharge chute becomes clogged during operation, proceed as follows to safely clean the chute and chute opening:

1. Release both the Auger Control Lever and the Traction/Auger Control Lock Lever.
2. Stop the engine by removing the ignition key.
3. Remove the clean-out tool from the clip which secures it to the rear of the auger housing.
4. Use the shovel-shaped end of the clean-out tool to remove any snow and ice in the discharge chute.



WARNING: Never use your hand to clear a clogged discharge chute. Shut off engine and remain behind handles until all moving parts have stopped before unlogging.

5. Refasten the clean-out tool to the mounting clip on the rear of the auger housing, re-start the engine.
6. While standing in the operator's position (behind the snow thrower), engage the auger clutch lever for a few seconds to clear any remaining snow or ice from the discharge chute before continuing to clear snow.

Tire Chains (Optional Equipment)

Tire chains may be used whenever extra traction is needed. Contact Customer Support as instructed on page 2 for information regarding price and availability.

Drift Cutters (Optional Equipment)

Drift cutters should be used when operating the snow thrower in heavy drift conditions.

On models so equipped, drift cutters are assembled to the auger housing inverted. Remove the carriage bolts by unthreading the hex nuts which secure them, and reinstall the drift cutters in their proper position before operating the snow thrower. See Figure 10.

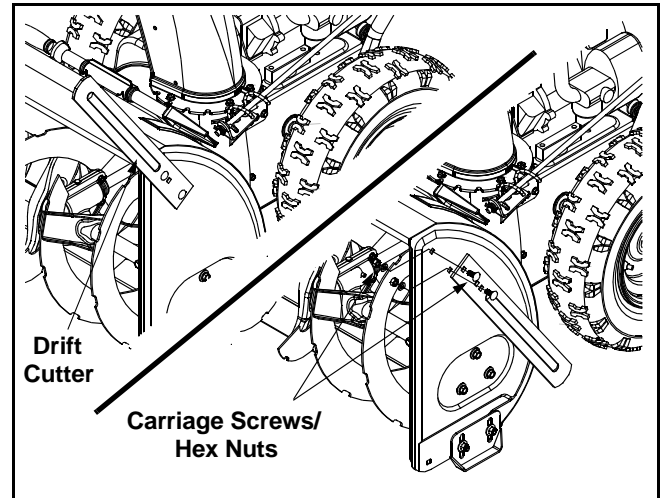

Figure 10

If your unit is not equipped with drift cutters, contact Customer Support as instructed on page 2 for information regarding price and availability.

Snow Thrower Model	Drift Cutter Kit
All models	OEM-390-679

Operating Tips

NOTE: Allow the engine to warm up for a few minutes as the engine will not develop full power until it reaches operating temperature.



WARNING: The muffler, engine and their surrounding areas become hot and can cause a burn. Do not touch.

- Discharge snow downwind whenever possible. Slightly overlap each previous path.
- Set the skid shoes 1/4" below the scraper bar for normal usage. The skid shoes may be adjusted upward for hard-packed snow. Adjust downward when using on gravel or crushed rock.
- Avoid possible starter freeze-up. Clean the snow thrower thoroughly after each use.

SECTION 5: MAKING ADJUSTMENTS



WARNING: NEVER attempt to make any adjustments while the engine is running, except where specified in the operator's manual.

Tire Pressure (Pneumatic Tires)

- The tires are over-inflated for shipping purposes. Before operating, check tire pressure and reduce, if necessary, to between 15 psi and 20 psi.

NOTE: If the tire pressure is not equal in both tires, the unit may pull to one side or the other.

Traction Control and Shift Lever

- To check the adjustment of the traction control and shift lever, proceed as follows:
- With the engine off, move the shift lever all the way forward to sixth (6) position. With the traction control released, push the snow thrower forward. The unit should move forward freely. Then engage the traction control grip. Wheels should stop turning.
- Now release the traction control grip, and push the unit again.
- Move the shift lever back to the fast reverse position, then all the way forward again. There should be no resistance in the shift lever, and wheels should keep turning.
- If you feel resistance when moving the shift lever or the wheels stop when they should not, loosen the jam nut on the traction control cable and unthread the cable one turn.
- If the wheels do not stop when you engage the traction control grip, loosen the jam nut on the traction control cable and thread the cable in one turn. Recheck the adjustment and repeat as necessary. Tighten the jam nut to secure the cable when correct adjustment is reached.



WARNING: Drain the gasoline out of snow thrower engine, place a piece of plastic film under the gas cap to avoid spillage before beginning the job.

To test further for correct adjustment, if necessary, proceed as follows:

- Tip the snow thrower forward, allowing it to rest on the auger housing. See Figure 11.

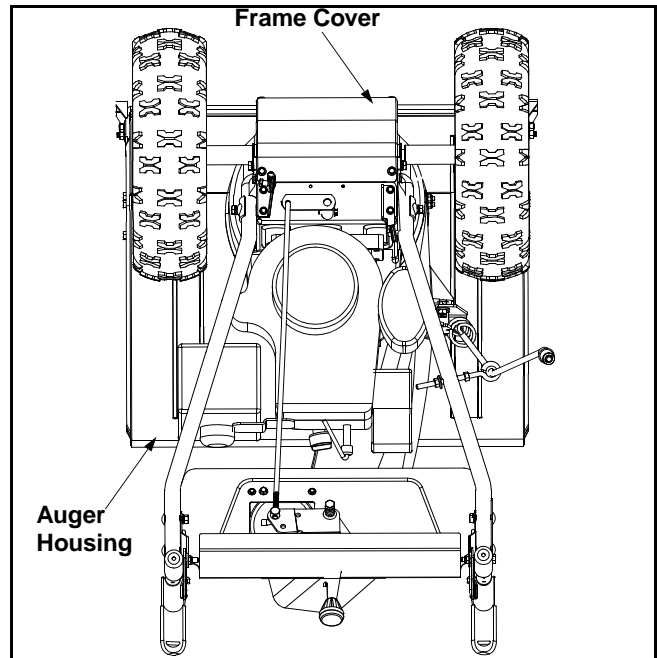

Figure 11

- Remove the frame cover underneath the snow thrower by removing six self-tapping screws.
- With the traction control released, there must be clearance between the friction wheel and the drive plate in all positions of the shift lever.
- With traction control engaged, the friction wheel must contact the drive plate. See Figure 12.

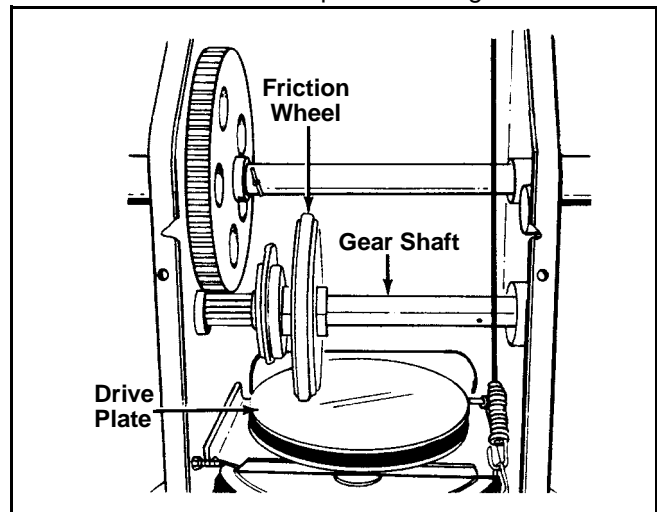

Figure 12

If adjustment is necessary:

- Loosen the jam nut on the traction drive cable and thread the cable in or out as necessary.
- Retighten the jam nut to secure the cable when correct adjustment is reached.
- Reassemble the frame cover.

NOTE: If you placed plastic film under the gas cap, be certain to remove it before operating the snow thrower.

Shift Rod

To adjust the shift rod, proceed as follows.

- Remove the hairpin clip and slide the shift rod connector up, to separate the upper shift rod from the lower shift rod. See Figure 13.
- Place the shift lever into the sixth (6) position.
- Rotate the shift arm clockwise (from the operator's position) as far as it will go.
- Thread the upper shift rod downward until the elbow on its lower end aligns with the hole found in the lower shift rod.

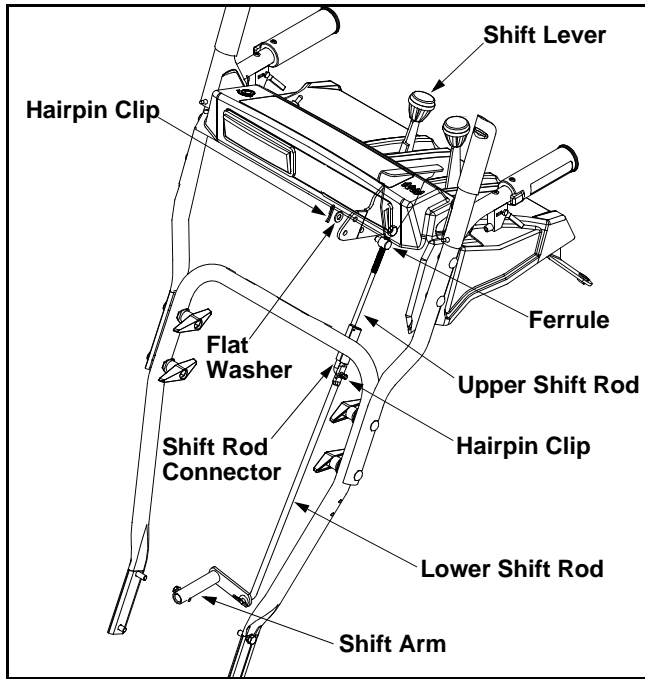

Figure 13

- Reconnect the upper shift rod to the lower shift rod by reinserting the hairpin clip removed earlier and sliding the shift rod connector back down into place.

IMPORTANT: Check for correct adjustment of the shift lever as instructed on page 11, before operating the snow thrower.

Auger Control

Refer to **Auger Control Test** on page 9 to adjust the auger control.

Chute Assembly

The distance snow is thrown can be adjusted by changing the angle of the chute assembly. Move the chute tilt control forward to decrease the distance, toward the rear to increase.

Skid Shoes

The space between the shave plate and the ground can be adjusted. For close snow removal, place skid shoes in the low position. Use middle or high position when area to be cleared is uneven. See Figure 14.

- Adjust skid shoes by loosening the four hex nuts and carriage bolts and moving skid shoes to desired position. Make certain the entire bottom surface of skid shoe is against the ground to avoid uneven wear on the skid shoes. Retighten nuts and bolts securely.

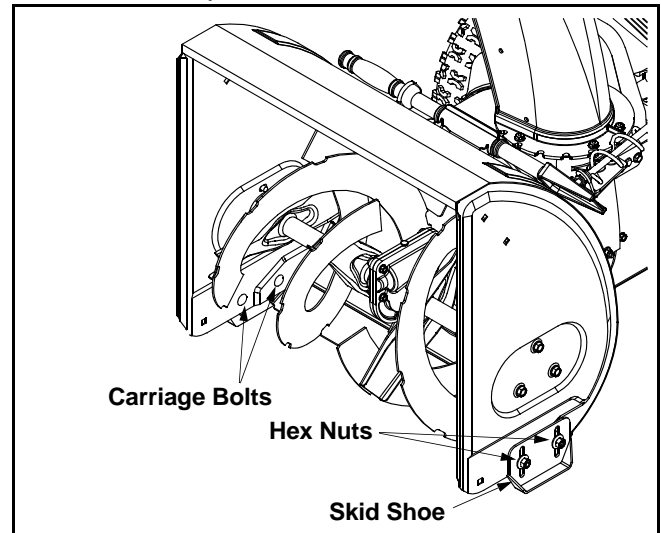

Figure 14



WARNING: Do not operate this snow thrower on gravel as loose gravel can be easily picked up and thrown by the auger causing injury to the operator and/or damage to the snow thrower.

Drive Wheels

The wheels may be adjusted for two different methods of operation. The adjustment is made by placing the click pins in one of two different holes on the right side of the unit. See Figure 15.

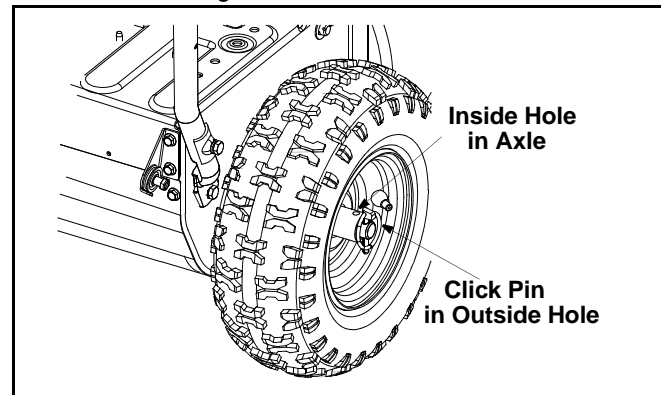

Figure 15

One Wheel Driving: Insert the click pin only through the outside hole of the axle (not the rim) on the right side of the snow thrower. This position gives power drive to the left wheel only, making the unit easier to maneuver.

Both Wheels Driving: Insert the click pin through the hole in the hub of the rim and the inside hole on the snow thrower's right axle. This position is good for heavy snow as there is power drive in both wheels.

IMPORTANT: Never operate the snow thrower with the click pin inserted through both the rim and the outside hole in the axle. Doing so can result in serious damage to the drive system.

SECTION 6: MAINTAINING YOUR SNOW THROWER



WARNING: Before servicing, repairing or inspecting, disengage all clutch levers and stop engine. Wait until all moving parts have come to a complete stop. Disconnect spark plug wire and ground it against the engine to prevent unintended starting.

Lubrication

Engine

- Refer to the engine manual for maintenance procedures and instructions.



WARNING: When following instructions in the engine manual for draining oil, be sure to protect frame to avoid oil dripping onto transmission parts.

Gear Shaft

- Lubricate the gear shaft with a good all-weather multi-purpose light grease at least once a season or after every 25 hours of operation.

IMPORTANT: Keep all grease and oil off friction wheel and drive plate.

Gear Case

- The auger gearbox has been filled with grease at the factory. If disassembled for repairs, lubricate with 1-1/2 ounces of grease, part no. 737-0168.

IMPORTANT: Do not overfill the gear case. Damage to the seals could result. Be sure the vent plug is free of grease in order to relieve pressure.

Wheels

- Oil or spray lubricant into bearings at least once a season. Pull the click pins and remove wheels, clean and coat axles with a multipurpose automotive grease. See Figure 16.

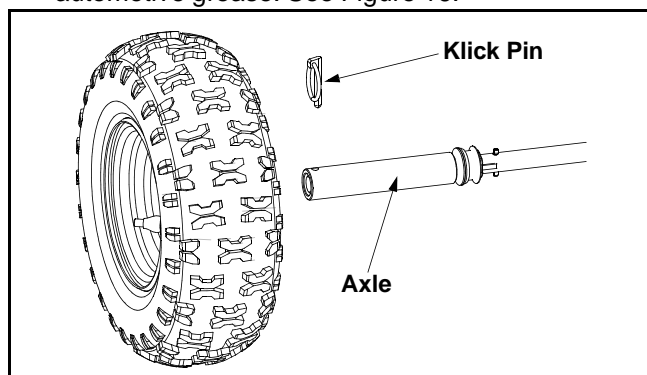

Figure 16

Auger Shaft

- At least once a season, remove shear bolts on auger shaft. Oil or spray lubricant inside shaft. Also lubricate the auger bearings at least once a season. See Figure 17.

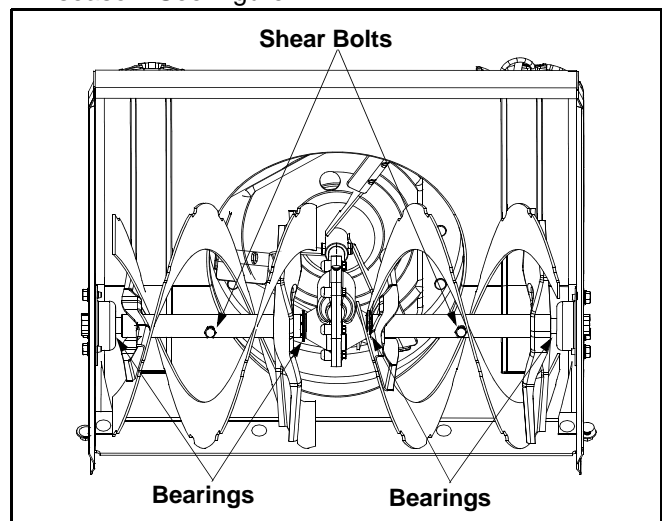

Figure 17

Chute Directional Control

- The worm gear on the chute directional control should be greased with multipurpose automotive grease.

Drive and Shifting Mechanism

- Remove rear cover. Oil any chains, sprockets, gears, bearings, shafts, and shifting mechanism at least once a season. Use engine oil or a spray lubricant. Avoid getting oil on rubber friction wheel and aluminum drive plate. See Figure 18.

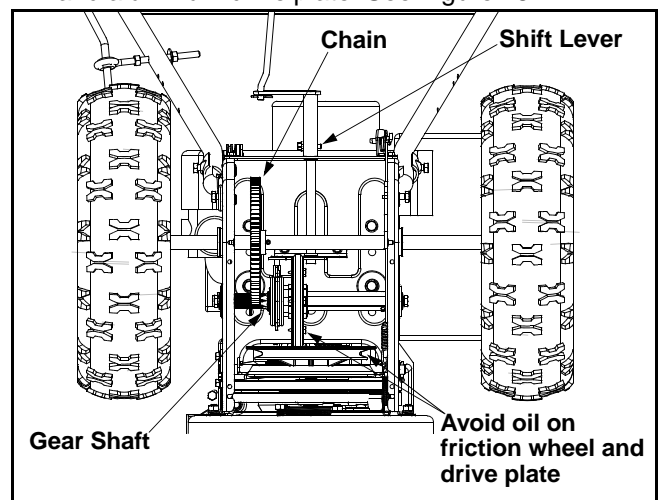

Figure 18

Traction Control / Auger Control Lock

The cams on the ends of the control rods which interlock the traction drive and auger drive controls must be lubricated at least once a season or every 25

hours of operation. The cams can be accessed beneath the handle panel. Use a multi-purpose automotive grease.

SECTION 7: SERVICE



WARNING: Before servicing, repairing, or inspecting, disengage all clutch levers and stop engine. Wait until all moving parts have come to a complete stop. Disconnect spark plug wire and ground it against the engine to prevent unintended starting.

Engine

Refer to the separate engine manual packed with your unit for all engine maintenance procedures.

Augers

The augers are secured to the spiral shaft with two shear bolts and hex lock nuts. If the snow thrower hits a foreign object or ice jam, the snow thrower is designed so that the bolts may shear. See Figure 17.

- If the augers will not turn, check to see if the bolts have sheared. Two replacement shear bolts and hex lock nuts have been provided in the snow thrower's hardware pack. When replacing bolts, spray an oil lubricant into shaft before inserting new bolts. For future use, order part number 710-0890A (shear bolt 5/16-18 x 1.5") and 712-0429 (hex lock nut 5/16-18).

IMPORTANT: NEVER replace the auger shear bolts with standard hex bolts. Any damage to the auger gearbox or other components as a result of doing so will NOT be covered by your snow thrower's warranty.

Shave Plate and Skid Shoes

The shave plate and skid shoes on the bottom of the snow thrower are subject to wear. They should be checked periodically and replaced when necessary.

- To remove skid shoes, remove the four carriage bolts, bell washers and hex nuts which attach them to the snow thrower. Reassemble new skid shoes with the four carriage bolts, bell washers (cupped side goes against skid shoes) and hex nuts. Make certain the skid shoes are adjusted to be level. See Figure 19.

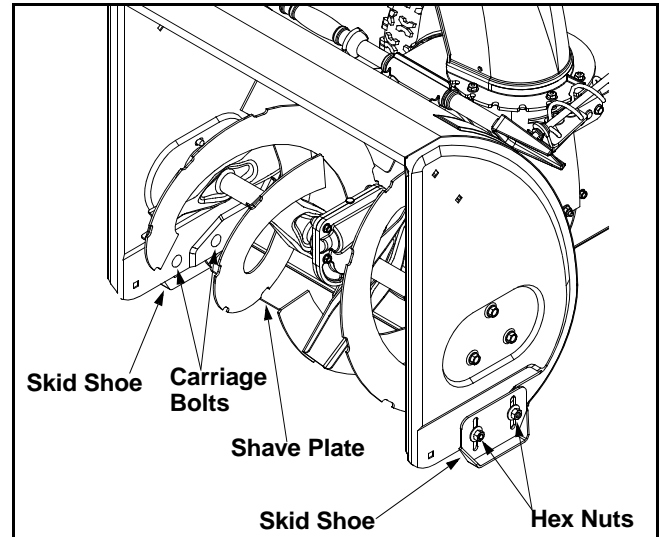

Figure 19

- To remove shave plate, remove carriage bolts, bell washers and hex nuts which attach it to the snow thrower housing.
- Reassemble new shave plate, making sure heads of the carriage bolts are to the inside of the housing. Tighten securely.

Belt Replacement



WARNING: Disconnect the spark plug wire from the spark plug and ground.

Auger Belts

- Remove the plastic belt cover on the front of the engine by removing the two self-tapping screws. See Figure 20.
- Drain the gasoline from the snow thrower, or place a piece of plastic under the gas cap.
- Tip the snow thrower up and forward so that it rests on the housing. See Figure 11.
- Remove six self-tapping screws from the frame cover underneath the snow thrower.

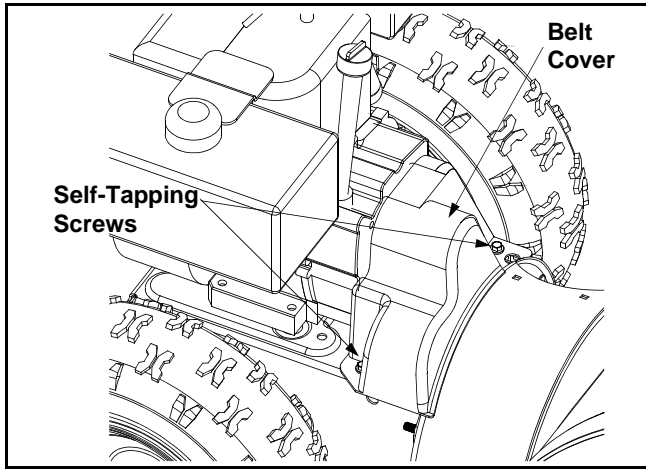

Figure 20

- Roll the front and rear auger belts off the engine pulley. See Figure 21.

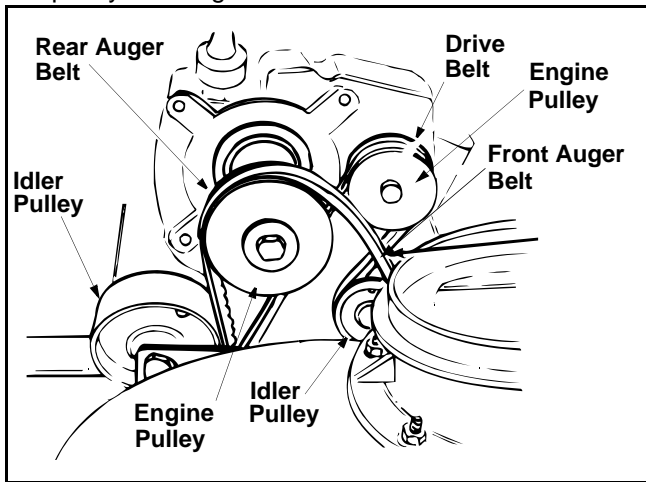

Figure 21

- Unhook the idler spring from the hex bolt on the auger housing. See Figure 22.
- Back out the stop bolt to allow the belts to slip between the bolt and auger pulley. See Figure 23.

NOTE: It may be necessary to loosen the six hex nuts that fasten the frame to the auger housing.

- Lift the rear auger belt from the auger pulley, and slip belt between the support bracket and the auger pulley. See Figure 22. Repeat this step for front auger belt.
- Replace both auger drive belts by following instructions in reverse order.

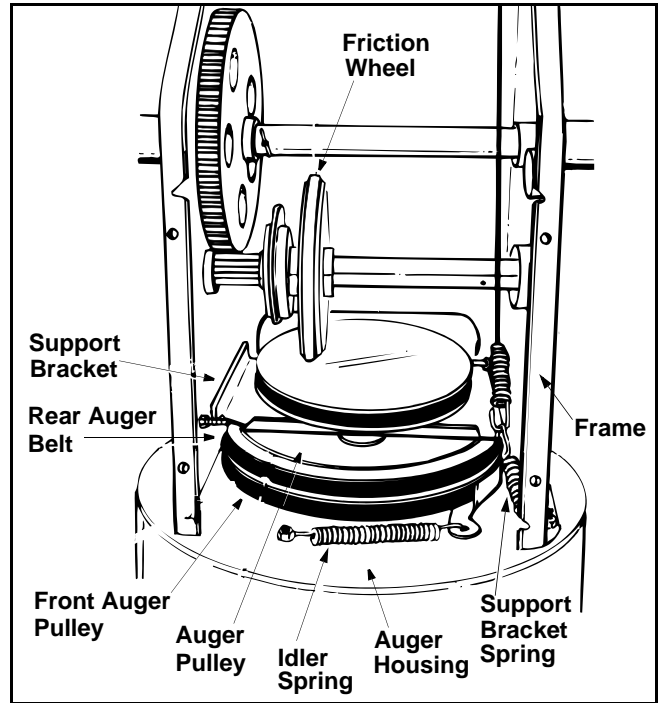

Figure 22

Drive Belt

- Follow steps 1 through 4 of previous instructions.
- Pull idler pulley up, and lift belt off engine pulley and friction wheel disc. See Figure 21.
- Back out the stop bolt until the support bracket rests on the auger pulley. See Figure 23.
- Slip belt between friction wheel and friction wheel disc. Remove and replace belt. Reassemble following the instructions in reverse order.

NOTE: The support bracket must rest on the stop bolt after the new belt has been assembled. See Figure 23.

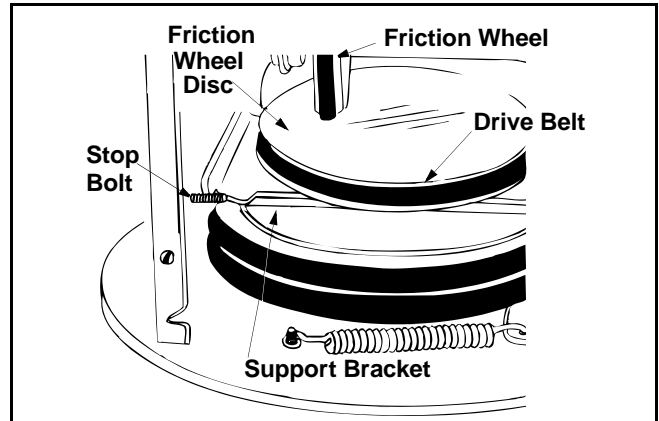

Figure 23

Changing Friction Wheel Rubber

The rubber on the friction wheel is subject to wear and should be checked after 25 hours of operation, and periodically thereafter. Replace the friction wheel rubber if any signs of wear or cracking are found as follows:

- Drain the gasoline from the snow thrower, or place a piece of plastic under the gas cap.
- Tip the snow thrower up and forward, so that it rests on the housing. See Figure 11.
- Remove the six self-tapping screws from the frame cover underneath the snow thrower.
- Remove the klick pins which secure the wheels, and remove the wheels from the axle.
- Using a wrench to hold the shaft, loosen, but do not completely remove, the hex nut and bell washer on left end of gear shaft. See Figure 24.

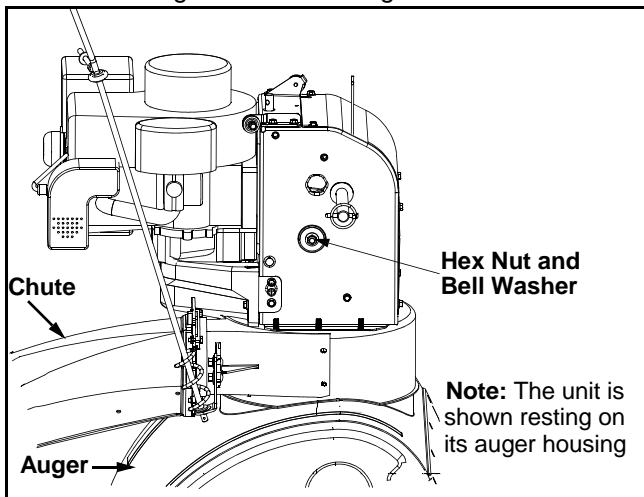

Figure 24

- Lightly tap the hex nut to dislodge the ball bearing from the right side of frame. Remove the hex nut and bell washer from left end of shaft.
- Slide the gear shaft to the right and slide the friction wheel assembly from the shaft.
- Remove the four screws from the friction wheel assembly. Remove the friction wheel rubber from between the plates. See Figure 25.
- Reassemble new friction wheel rubber to the friction wheel assembly, tightening the four screws in rotation and with equal force.

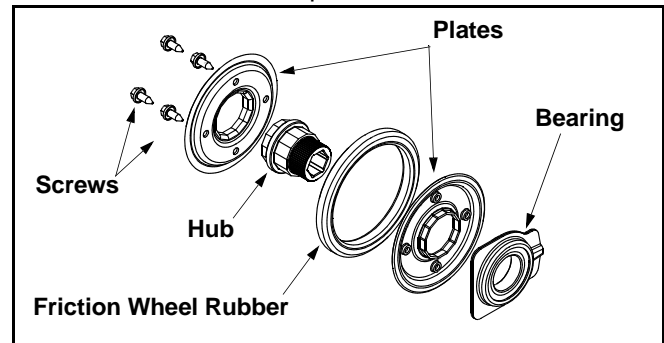

Figure 25

- Slide friction wheel assembly back onto the gear shaft. Be sure to align the pin on the shift rod with hole in the friction wheel assembly. See Figure 22.
- Reassemble gear shaft and the wheels. Reattach the frame cover.

SECTION 8: OFF-SEASON STORAGE



WARNING: Never store engine with fuel in tank indoors or in enclosed, poorly ventilated areas where fuel fumes may reach an open flame, spark or pilot light as on a furnace, water heater, clothes dryer, or other gas appliance.



WARNING: Drain fuel into an approved container outdoors, away from an open flame. Allow engine to cool. Extinguish cigarettes, cigars, pipes, and other sources of ignition prior to draining fuel. Fuel left in engine for extended periods deteriorates and will cause starting problems.

If unit is to be stored over 30 days, prepare for storage as follows:

- Remove gasoline from carburetor and fuel tank to prevent gum deposits from forming on these parts and causing possible malfunction of engine.
- Run engine until fuel tank is empty and engine stops due to lack of fuel.
- Drain carburetor by pressing upward on bowl drain, located below the carburetor cover.

NOTE: Fuel stabilizer is an acceptable alternative in minimizing the formation of fuel gum deposits during storage. Do not drain carburetor if using fuel stabilizer.

- Wipe equipment with an oiled rag to prevent rust.
- Remove spark plug and pour one ounce of engine oil through spark plug hole into cylinder. Cover spark plug hole with rag. Crank engine several times to distribute oil. Replace spark plug.

- Remove all dirt from exterior of engine and equipment.
- Follow lubrication recommendations on page 13.

NOTE: When storing any type of power equipment in an poorly ventilated or metal storage shed, care should be taken to rustproof the equipment, especially springs, cables and all moving parts.

SECTION 9: TROUBLE SHOOTING GUIDE

Trouble	Possible Cause(s)	Corrective Action
Engine fails to start	Fuel tank empty, or stale fuel. Blocked fuel line. Choke not in ON position Faulty spark plug. Key not in switch on engine. Spark plug wire disconnected. Primer button not depressed. Fuel shut-off valve closed (if so equipped).	Fill tank with clean, fresh gasoline. Fuel may not last over thirty days unless a fuel stabilizer is used. Clean fuel line. Move switch to ON position Clean, adjust gap or replace. Insert key. Connect spark plug wire. Refer to the engine manual packed with your unit. Open fuel shut-off valve.
Engine runs erratic	Unit running on CHOKE. Blocked fuel line or stale fuel. Water or dirt in fuel system. Carburetor out of adjustment.	Move choke lever to OFF position. Clean fuel line; fill tank with clean fresh gasoline. Fuel may not last over thirty days unless a fuel stabilizer is used. Drain fuel tank. Refill with fresh fuel. Refer to the engine manual packed with your unit or have carburetor adjusted by an authorized service dealer.
Loss of power	Spark plug wire loose. Gas cap vent hole plugged. Exhaust port plugged.	Connect and tighten spark plug wire. Remove ice and snow from cap. Be certain vent hole is clear. Clean-see Maintenance section of engine manual.
Engine overheats	Carburetor not adjusted properly. Incorrect fuel mixture.	Refer to the engine manual packed with your unit or have carburetor adjusted by an authorized service dealer. Drain fuel tank. Refill with proper fuel mixture.
Excessive vibration	Loose parts or damaged auger.	Stop engine immediately and disconnect spark plug wire. Tighten all bolts and nuts. Make all necessary repairs. If vibration continues, have unit serviced by an authorized service dealer.
Unit fails to propel itself	Incorrect adjustment of drive cable. Drive belt loose or damaged.	Adjust drive cable. Refer to Adjustment section of this manual. Replace drive belt. Refer to Belt Replacement on page 14.
Unit fails to discharge snow	Discharge chute clogged. Foreign object lodged in auger. Incorrect adjustment of drive cable. Drive belt loose or damaged. Shear bolt(s) sheared	Stop engine immediately and disconnect spark plug wire. Clean discharge chute and inside of auger housing. Stop engine immediately and disconnect spark plug wire. Remove object from auger. Adjust drive cable. Refer to Adjustment section of this manual. Replace drive belt. Refer to Belt Replacement on page 14. Replace shear bolt(s)

NOTE: For repairs beyond the minor adjustments listed above, contact your nearest authorized service dealer or call 1-800-800-7310 for the Customer Support Center. Refer to separate engine manual packed with your snow thrower for more engine related information.

SECTION 10: PARTS LIST

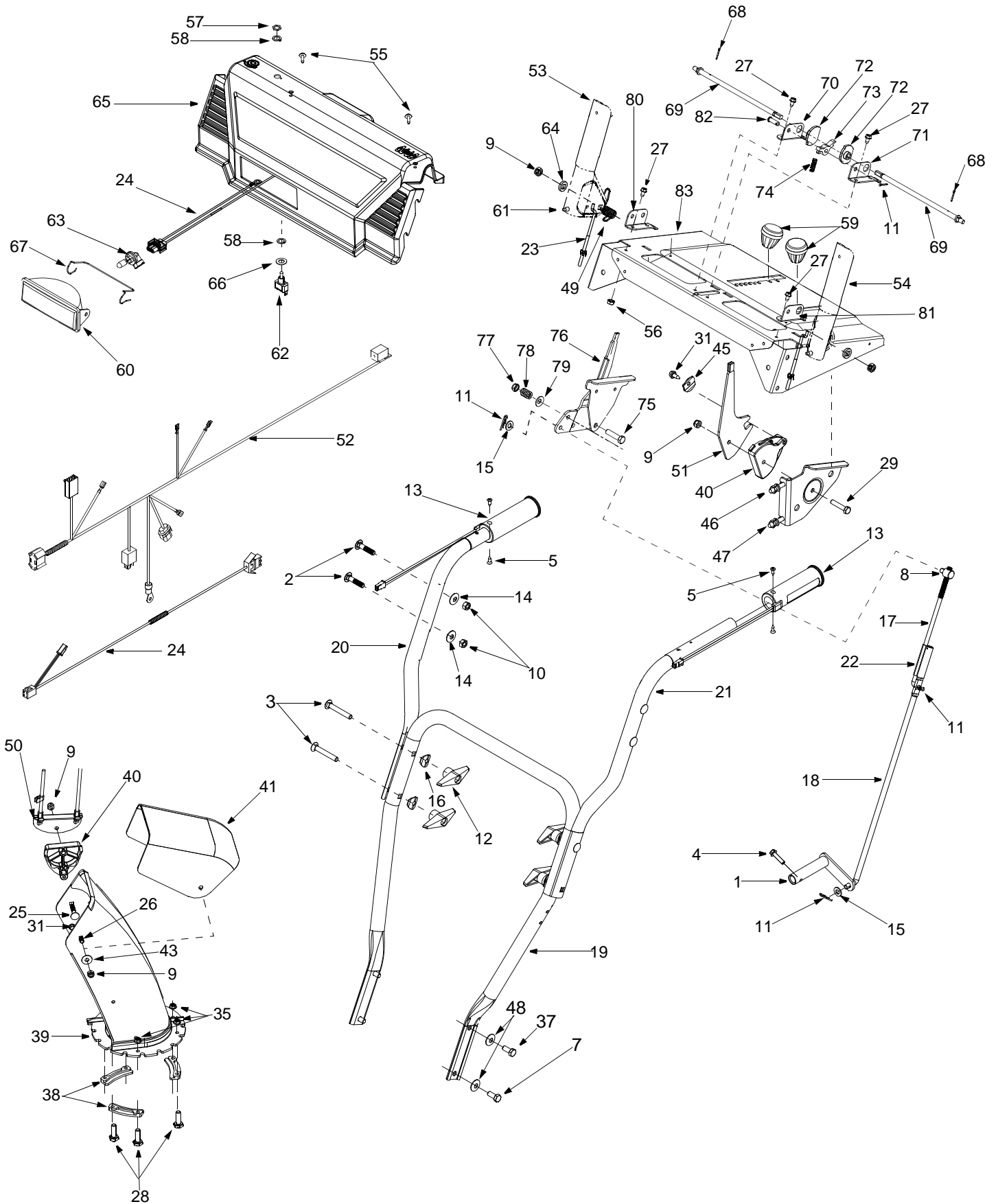

Model H660G

Ref. No.	Part No.	Part Description	Ref. No.	Part No.	Part Description
1.	684-0008A	Shift Arm Assembly	47.	746-0901	Control Cable
2.	710-0458	Carriage Bolt 5/16-18 x 1.75"	48.	736-0119	Lock Washer 5/16
3.	710-0449	Carriage Bolt 5/16-18 x 2.25"	49.	732-0746	Torsion Spring
4.	710-0788	TT Screw 1/4-20 x 1"	50.	784-5594	Cable Bracket
5.	710-0837	C-Sunk Screw #10-16x 0.625"	51.	784-5604	Handle: Chute Tilt
7.	710-1880	Hex Screw 5/16-18 x.75"	52.	629-1094	Harness Assembly: Upper
8.	711-0677	Ferrule	53.	684-0036A	Handle Assembly RH
9.	712-0429	Hex Lock Nut 5/16-18	54.	684-0037B	Handle Assembly LH
10.	712-3068	Hex Nut 5/16-18	55.	710-1003	Special Hex Screw
11.	714-0104	Cotter Pin	56.	712-0271	Hex Sems Nut: 1/4-20
12.	720-0284	Handle Knob	57.	712-0693	Hex Nut
13.	725-1757	Heated Grip	58.	716-0398	Lock Ring: Toggle Switch
14.	736-0242	Belleville Washer	59.	720-0232	Shift Knob
15.	736-0275	Flat Washer	60.	725-1672	Lamp Housing
16.	736-0451	Saddle Washer	61.	735-0199A	Rubber Bumper
17.	747-0620A	Shift Rod: Upper	62.	725-1756	Toggle Switch: Single Switch
18.	747-0621	Shift Rod: Lower	63.	725-1759	Halogen Lamp: 50W, 12V
19.	749-0951	Lower Handle	64.	736-0509	Washer
20.	749-0952A	Upper Handle: L Style RH	65.	731-04450	Handle Panel
21.	749-0953A	Upper Handle: L Style LH	66.	736-0226	Flat Washer
22.	750-0963	Connector: Shift Rod	67.	747-1136	Headlight Retainer
23.	746-0778	Z Cable Fitting	68.	714-0507	Cotter Pin: 3/32 x.75
24.	629-0059	Light Harness	69.	747-0877	Cam Rod
25.	710-0262	Carriage Bolt: 5/16-18 x 1.5"	70.	784-5680	RH Handle Support Bracket
26.	710-04071	Carriage Bolt: 5.16-18 x 1.0"	71.	784-5679	LH Handle Support Bracket
27.	710-0599	TT Screw: 1/4-20 x 0.5"	72.	748-0362	Cam Handle Lock
28.	710-3015	Hex Screw 1/4-20	73.	748-0363	Handle Lock Pawl
29.	710-0805	Hex Screw: 5/16-18 x 1.5"	74.	732-0145	Compression Spring:.36 x 1.0
31.	710-0895	Hex Screw AB:1/4-15 x 0.750"	75.	710-0459A	Hex Cap Screw: 3/8-24 x 1.5
35.	712-3027	Hex Flange Lock Nut	76.	784-5619A	Shift Handle
37.	710-0643	Hex Screw 5/16-18	77.	712-0116	Jam Nut, 3/8-24
38.	731-0851A	Chute Flange Keeper	78.	732-0193	Comp. Spring:.39 x.6 x.88
39.	731-1300B	Lower Chute	79.	736-0105	Bell Washer
40.	731-1313C	Cable Guide: Chute Tilt	80.	784-5682	RH Handle Support Bracket
41.	731-04427	Upper Chute	81.	784-5681	LH Handle Support Bracket
43.	736-0159	5/16 Washer	82.	711-0653	Clevis Pin
45.	736-0506	Special Washer	83.	684-0103	Handle Panel
46.	746-0896	Control Cable			

Model H660G

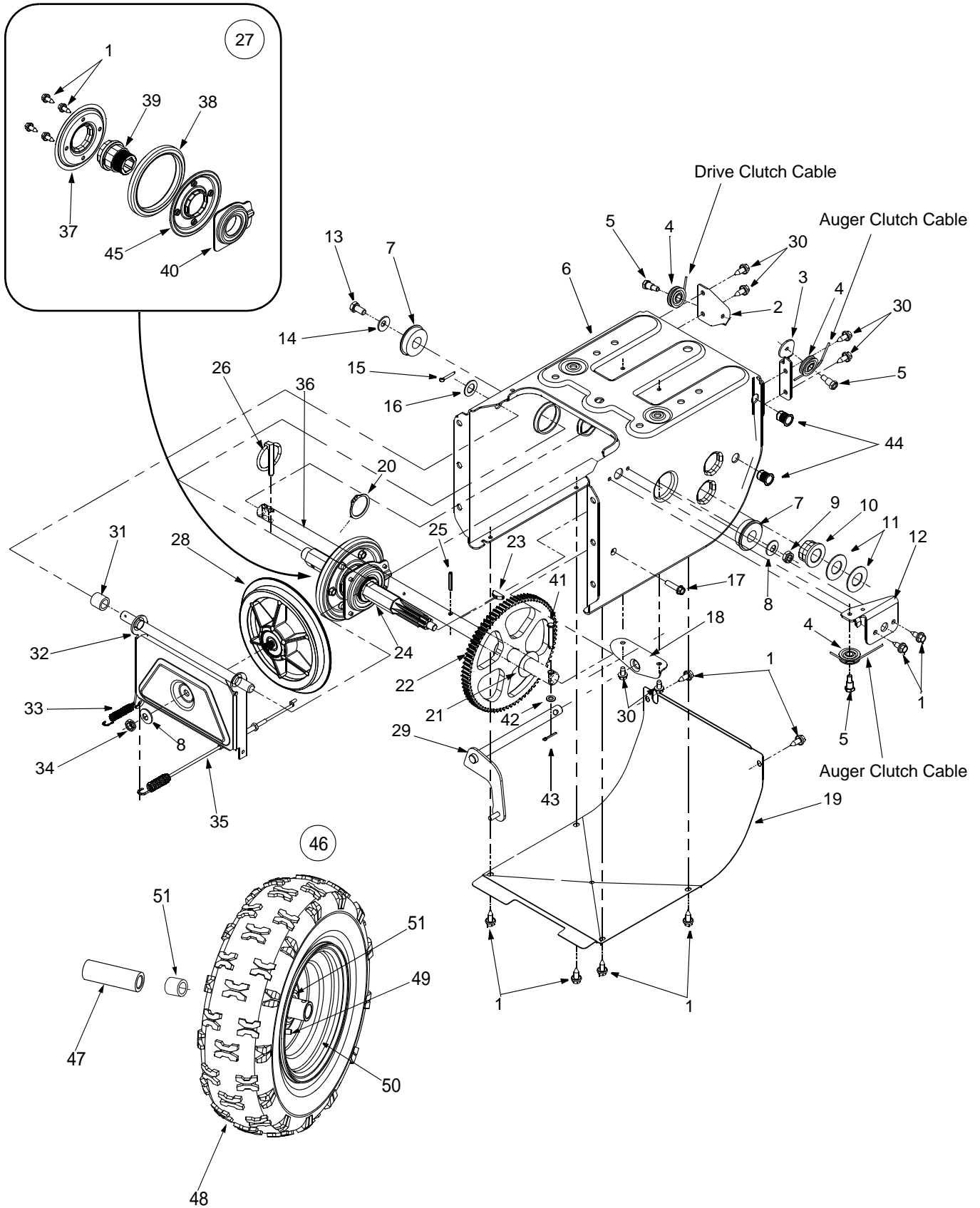

Model H660G

REF. NO.	PART NO.	DESCRIPTION	REF. NO.	PART NO.	DESCRIPTION
1	710-1652	Self-tapping Screw, 1/4-20 x.625	27	684-0042C	Friction Wheel Assembly
2	784-5688	Drive Cable Guide Bracket	28	656-0012A	Friction Disc Wheel
3	784-5687A	Auger Clutch Cable Bracket	29	684-0013B	Wheel Shift Rod Assembly
4	756-0625	Cable Roller	30	710-0599	Self-tapping Screw, 1/4-20 x.5
5	738-0924	Hex Screw 1/4-28	31	748-0190	Spacer
6	784-5630B	Frame Assembly	32	684-0021	Friction Wheel Bracket Assembly
7	741-0563	Ball Bearing	33	732-0264	Extension Spring
8	736-0105	Bell Washer	34	712-0711	Jam Nut 3/8-24
9	712-0116	Lock Jam Nut	35	746-0898B	Drive Cable
10	741-04026	Hex Flange Bearing	36	738-0830	Axle 16" Wheels
11	736-0188	Flat Washer†	37	790-00010	Friction Plate
12	784-5689A	Front Support Guide Bracket	38	735-0243B	Friction Wheel Rubber
13	710-0538	Lock Hex Screw	39	718-0301A	Friction Wheel Hub
14	736-0242	Bell Washer.340 ID x.872 OD	40	618-0063A	Friction Wheel Bearing Assembly
15	714-0474	Cotter Pin	41	711-1364	Clevis Pin, 1/4 x 1.3725
16	736-0160	Flat Washer.536 ID x.930 OD	42	736-0142	Flat Washer,.281 x.5 x.063
17	710-0809	Self-tapping Screw, 1/4-20 x 1.25	43	714-0507	Cotter Pin,.75
18	784-5590	Frame Shift Bracket	44	712-0703A	Insert Nut, 5/16-18
19	784-5638A	Frame Cover	45	790-00011	Friction Plate
20	716-0102	Snap Ring	46	734-1712A	Wheel Assembly Comp. 16 x 6.5
21	736-0351	Flat Washer.760 ID x.50 OD	47	731-04043	Spacer
22	717-1445	80 Tooth Gear	48	734-1525	Tire Only
23	714-0126	Key		723-0430	Tire Chain (Not Shown)
24	717-04094	7-Tooth Shaft	49	734-0255	Air Valve
25	715-0249	Roll Pin	50	734-1711A	Rim Only
26	714-0143	Klik Pin	51	741-0401	Sleeve Bearing

† Use more than one washer on either side, only if necessary to reduce axle-play.

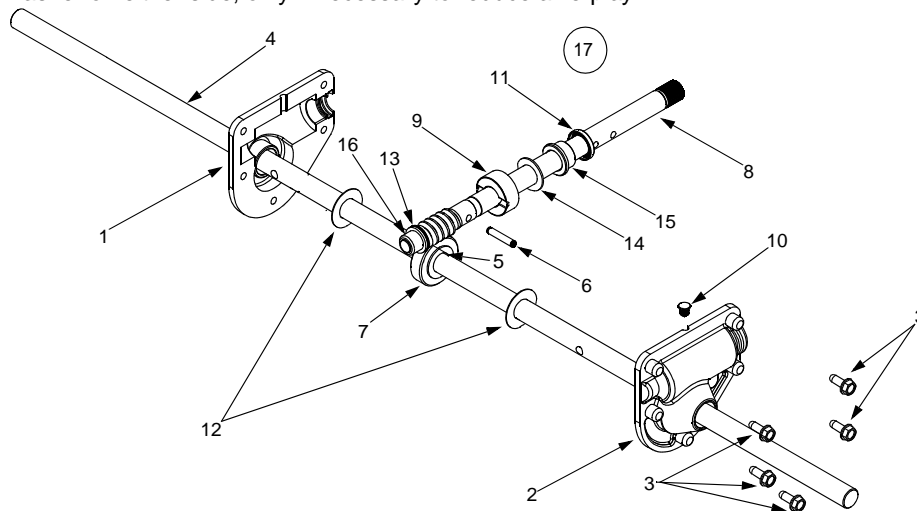

REF. NO.	PART NO.	DESCRIPTION	REF. NO.	PART NO.	DESCRIPTION
1	618-0123	RH Reducer Housing	10	721-0325	Grease Plug
2	618-0124	LH Reducer Housing	11	721-0327	Grease Seal
3	710-0642	Hex Screw 1/4-20 x.75	12	736-0351	Flat Washer.76 x 1.5 x.030
4	711-0910A	Spiral Axle 28"	13	736-0369	Flat Washer.508 x 1.0 x.020
5	714-0161	Key	14	736-0445	Flat Washer.76 x 1.5 x.060
6	715-0143	Spiral Pin	15	741-0662	Flange Bearing.75 x 1.0 x.59
7	717-0528	Worm Gear, 20T	16	741-0663	Flange Bearing.75 x 1.0 x.925
8	717-0526	Worm Shaft	17	618-0122A	Gearbox Ass'y. Complete 28"
9	718-0186	Thrust Collar			

NOTE: When rebuilding a gearbox assembly, include 1.5 oz. of Alvania EP Lead-Free Grease (Part No. 737-0168)

Model H660G

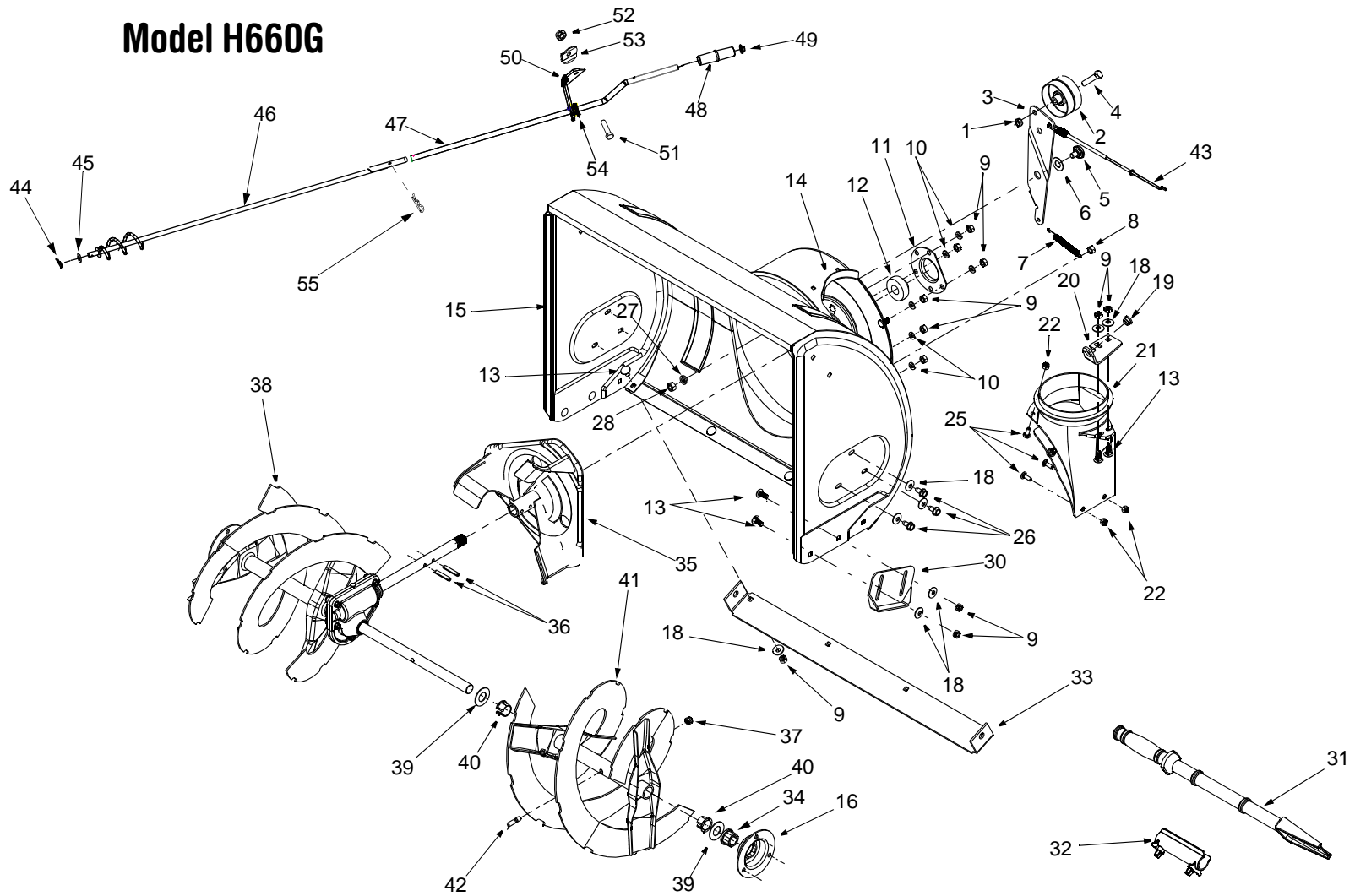

REF. NO.	PART NO.	DESCRIPTION	REF. NO.	PART NO.	DESCRIPTION
1	712-0116	Lock Jam Nut 3/8-24	31	731-2643	Chute Clean-out Tool
2	756-0178	Flat Idler	32	731-2635	Mount, Chute Clean-out Tool
3	784-5632B	Auger Idler Arm	33	784-5582A	28" Shave Plate
4	710-0459A	Hex Cap Screw 3/8-24 x 1.50	34	741-0245	Hex Flange Bearing
5	738-0281	Shoulder Screw	35	684-0065	Impeller Assembly
6	736-0167	Flat Washer, .565 x 1.25 x .02	36	715-0114	Pin
7	732-0611	Extension Spring	37	712-0429	Lock Nut 5/16-18
8	712-3068	Hex Nut 5/16-18	38	605-5196A	Spiral 28" RH
9	712-3010	Hex Nut 5/16-18	39	736-0188	Flat Washer
10	736-0119	Lock Washer 5/16	40	741-0493A	Flange Bushing
11	05931A	Housing	41	605-5197A	Spiral 28" LH
12	741-0309	Ball Bearing	42	710-0890A	Shear Bolt 5/16-18 x 1.5
13	710-0451	Carriage Bolt 5/16-18 x.75	43	746-0897	Drive Cable
14	705-5226	Reinforcement Chute	44	714-0104	Hairpin Clip
15	684-0041D	28" Housing Assembly	45	736-0185	Flat Washer
16	784-5618	Bearing Housing	46	684-0053B	Chute Crank Assembly
18	736-0242	Bell Washer	47	747-0737	Upper Chute Crank
19	741-0475	Bushing	48	720-0201A	Chute Crank Knob
20	784-5647	Chute Crank Bracket	49	726-0100	Push Cap
21	731-1379C	Chute Adapter	50	705-5266	Chute Crank Bracket
22	712-3027	Hex Flange Lock Nut 1/4-20	51	710-3015	Hex Screw 1/4-20
25	710-0703	Carriage Screw 1/4-20 x.75	52	712-0287	Hex Nut 1/4-20
26	710-0726	Screw 5/16-12	53	736-0270	Bell Washer
27	736-0169	Lock Washer 3/8	54	741-0475	Plastic Bushing
28	712-0798	Hex Nut 3/8-16	55	714-0145	Hairpin Clip
30	784-5580	Snow Shoe			

Model H660G

IMPORTANT: For a properly working machine, use Factory Approved Parts.
V-BELTS are specially designed to engage and disengage safely. A substitute (non OEM) V-Belt can be dangerous by not disengaging completely.

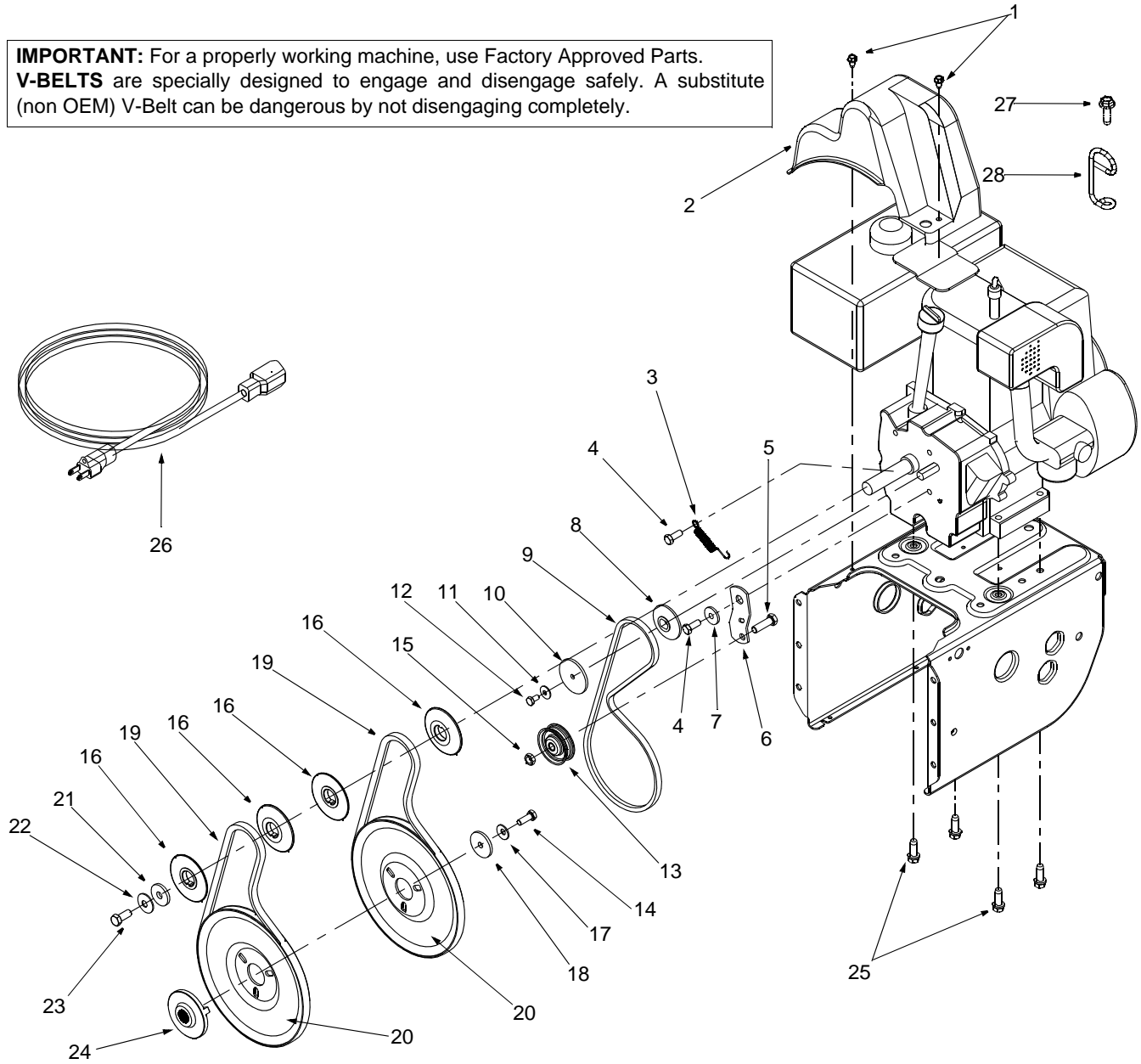

REF. NO.	PART NO.	DESCRIPTION	REF. NO.	PART NO.	DESCRIPTION
1	710-1652	Hex Washer Screw 1/4-20 x.625	15	712-0181	Lock Jam Nut 3/8-16
2	731-1324	Belt Cover	16	756-0569	Pulley Half
3	732-0710	Extension Spring	17	736-0242	Bell Washer
4	710-0627	Hex Screw 5/16-24 x.75	18	736-0505	Flat Washer
5	710-3005	Hex Cap Screw 3/8-16 x 1.25	19	754-0430B	Belt
6	05896A	Drive Clutch Idler Bracket	20	756-0967	Auger Pulley
7	748-0234	Shoulder Spacer	21	736-0247	Flat Washer 3/8 x 1.25 OD
8	756-0987	Pulley Half	22	736-0331	Bell Washer
9	754-0346	V-Belt	23	710-0696	Hex Cap Screw 3/8-24
10	756-0986	Pulley Half	24	748-0360	Pulley Adapter
11	736-0270	Bell Washer	25	710-0654A	Hex Screw 3/8-16 x 1.0
12	710-0230	Hex Cap Screw 1/4-28 x.50	26	629-0071	Extension Cord, Three-Prong
13	756-0313	Flat Idler	27	710-0602	Self Tapping Screw 5/16-18
14	710-1245B	Lock Hex Cap Screw 5/16-24	28	732-0705	Cable Guide

MANUFACTURER'S LIMITED WARRANTY FOR:



The limited warranty set forth below is given by MTD LLC with respect to new merchandise purchased and used in the United States, its possessions and territories.

"MTD" warrants this product against defects in material and workmanship for a period of two (2) years commencing on the date of original purchase and will, at its option, repair or replace, free of charge, any part found to be defective in materials or workmanship. This limited warranty shall only apply if this product has been operated and maintained in accordance with the Operator's Manual furnished with the product, and has not been subject to misuse, abuse, commercial use, neglect, accident, improper maintenance, alteration, vandalism, theft, fire, water, or damage because of other peril or natural disaster. Damage resulting from the installation or use of any part, accessory or attachment not approved by MTD for use with the product(s) covered by this manual will void your warranty as to any resulting damage.

Normal wear parts or components thereof are subject to separate terms as follows: All normal wear parts or component failures will be covered on the product for a period of 90 days regardless of cause. After 90 days, but within the two year period, normal wear part failures will be covered ONLY IF caused by defects in materials or workmanship of OTHER component parts. Normal wear parts and components include, but are not limited to: batteries, belts, blades, blade adapters, grass bags, rider deck wheels, seats, snow thrower skid shoes, shave plates, auger spiral rubber, and tires.

HOW TO OBTAIN SERVICE: Warranty service is available, WITH PROOF OF PURCHASE, through your local authorized service dealer. To locate the dealer in your area, check your Yellow Pages, or contact MTD LLC at P.O. Box 361131, Cleveland, Ohio 44136-0019, or call 1-800-800-7310 or 1-330-220-4683 or log on to our Web site at www.mtdproducts.com.

This limited warranty does not provide coverage in the following cases:

- a. The engine or component parts thereof. These items may carry a separate manufacturer's warranty. Refer to applicable manufacturer's warranty for terms and conditions.
- b. Log splitter pumps, valves, and cylinders have a separate one year warranty.
- c. Routine maintenance items such as lubricants, filters, blade sharpening, tune-ups, brake adjustments, clutch adjustments, deck adjustments, and normal deterioration of the exterior finish due to use or exposure.

- d. MTD does not extend any warranty for products sold or exported outside of the United States, its possessions and territories, except those sold through MTD's authorized channels of export distribution.
- e. Replacement parts that are not genuine MTD parts.
- f. Service completed by someone other than an authorized service dealer.
- g. Transportation charges and service calls.

No implied warranty, including any implied warranty of merchantability of fitness for a particular purpose, applies after the applicable period of express written warranty above as to the parts as identified. No other express warranty, whether written or oral, except as mentioned above, given by any person or entity, including a dealer or retailer, with respect to any product, shall bind MTD. During the period of the warranty, the exclusive remedy is repair or replacement of the product as set forth above.

The provisions as set forth in this warranty provide the sole and exclusive remedy arising from the sale. MTD shall not be liable for incidental or consequential loss or damage including, without limitation, expenses incurred for substitute or replacement lawn care services or for rental expenses to temporarily replace a warranted product.

Some states do not allow the exclusion or limitation of incidental or consequential damages, or limitations on how long an implied warranty lasts, so the above exclusions or limitations may not apply to you.

In no event shall recovery of any kind be greater than the amount of the purchase price of the product sold. **Alteration of safety features of the product shall void this warranty.** You assume the risk and liability for loss, damage, or injury to you and your property and/or to others and their property arising out of the misuse or inability to use the product.

This limited warranty shall not extend to anyone other than the original purchaser or to the person for whom it was purchased as a gift.

HOW STATE LAW RELATES TO THIS WARRANTY: This limited warranty gives you specific legal rights, and you may also have other rights which vary from state to state.

IMPORTANT: Owner must present Original Proof of Purchase to obtain warranty coverage.

MTD LLC, P.O. BOX 361131 CLEVELAND, OHIO 44136-0019; Phone: 1-800-800-7310, 1-330-220-4683